

MMBT3906-HF (PNP)

RoHS Device
Halogen Free

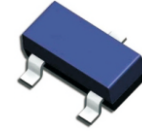

Features

- Epitaxial planar die construction
- As complementary type, the NPN transistor MMBT3904-HF is recommended

Mechanical data

- Case: SOT-23, molded plastic.

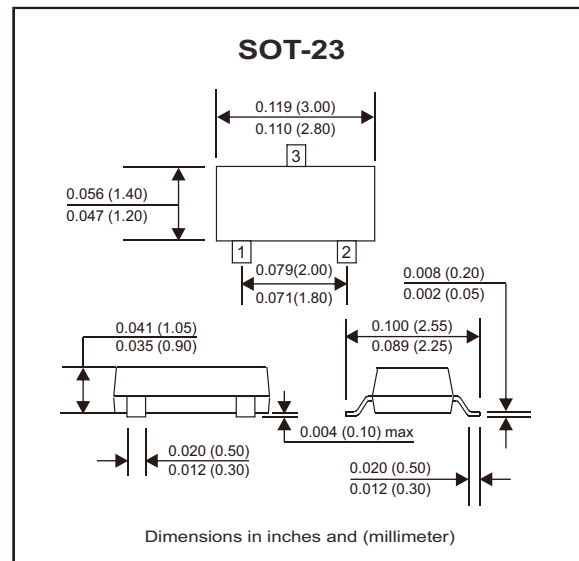

Circuit Diagram

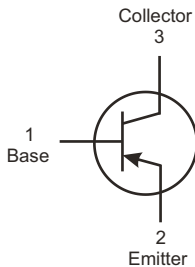

Maximum Ratings (at TA=25°C unless otherwise noted)

Parameter	Symbol	Value	Unit
Collector-Base voltage	V _{CB0}	-40	V
Collector-Emitter voltage	V _{CE0}	-40	V
Emitter-Base voltage	V _{EB0}	-5	V
Collector current-continuous	I _C	-200	mA
Collector dissipation	P _C	200	mW
Junction temperature	T _J	150	°C
Storage temperature range	T _{STG}	-55 to +150	°C
Thermal resistance from junction to ambient	R _{θJA}	625	°C/W

Electrical Characteristics (at TA=25°C unless otherwise noted)

Parameter	Conditions	Symbol	Min	Max	Unit
Collector-Base breakdown voltage	$I_C = -10\mu A, I_E = 0$	$V_{(BR)CBO}$	-40		V
Collector-Emitter breakdown voltage	$I_C = -1mA, I_B = 0$	$V_{(BR)CEO}$	-40		V
Emitter-Base breakdown voltage	$I_E = -10\mu A, I_C = 0$	$V_{(BR)EBO}$	-5		V
Collector cut-off current	$V_{CB} = -40V, I_E = 0$	I_{CBO}		-50	nA
Collector cut-off current	$V_{CE} = -30V, V_{EB(off)} = -3V$	I_{CEX}		-100	nA
Emitter cut-off current	$V_{EB} = -5V, I_C = 0$	I_{EBO}		-100	nA
DC current gain	$V_{CE} = -1V, I_C = -10mA$	$h_{FE(1)}$	100	300	
	$V_{CE} = -1V, I_C = -50mA$	$h_{FE(2)}$	60		
	$V_{CE} = -1V, I_C = -100mA$	$h_{FE(3)}$	30		
Collector-Emitter saturation voltage	$I_C = -50mA, I_B = -5mA$	$V_{CE(sat)}$		-0.3	V
Base-Emitter saturation voltage	$I_C = -50mA, I_B = -5mA$	$V_{BE(sat)}$		-0.95	V
Transition frequency	$V_{CE} = -20V, I_C = -10mA$ $f = 100MHz$	f_T	300		MHz
Delay time	$V_{CC} = -3V, V_{BE(off)} = -0.5V$ $I_C = -10mA, I_{B1} = -1mA$	t_d		35	nS
Rise time	$V_{CC} = -3V, V_{BE(off)} = -0.5V$ $I_C = -10mA, I_{B1} = -1mA$	t_r		35	nS
Storage time	$V_{CC} = -3V, I_C = -10mA, I_{B1} = I_{B2} = -1mA$	t_s		225	nS
Fall time	$V_{CC} = -3V, I_C = -10mA, I_{B1} = I_{B2} = -1mA$	t_f		75	nS

Rating and Characteristic Curves (MMBT3906-HF)

Fig.1 - Static Characteristic

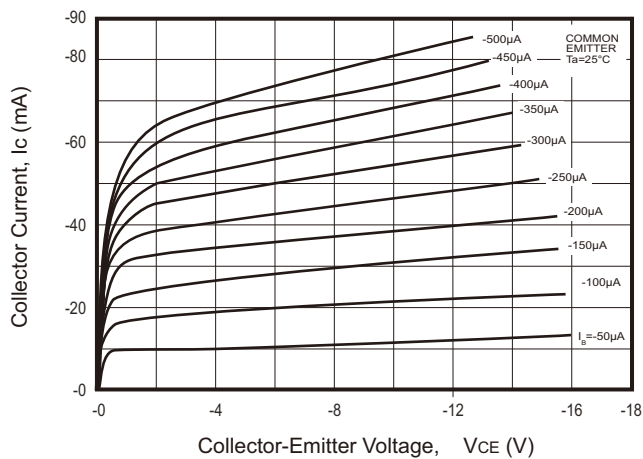
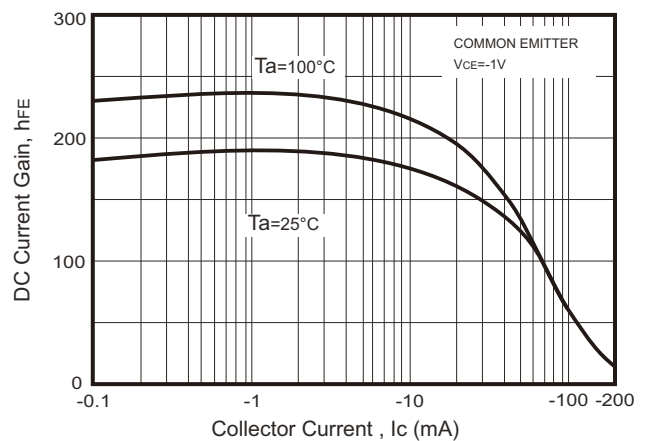

Fig.2 - $h_{FE} - I_C$



Rating and Characteristic Curves (MMBT3906-HF)

Fig. 3 - $V_{CEsat} - I_c$

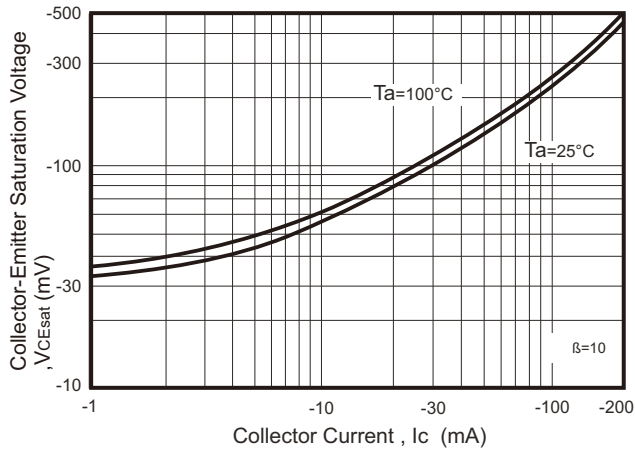

Fig. 4 - $V_{BEsat} - I_c$

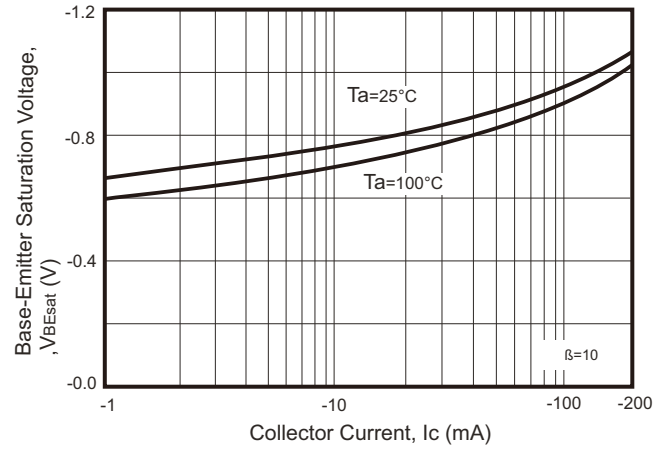

Fig. 5 - $I_c - V_{BE}$

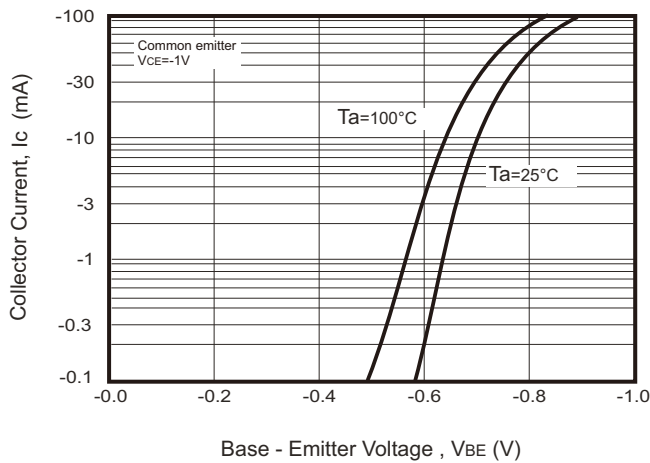

Fig. 6 - $C_{ob}/C_{ib} - V_{CB}/V_{EB}$

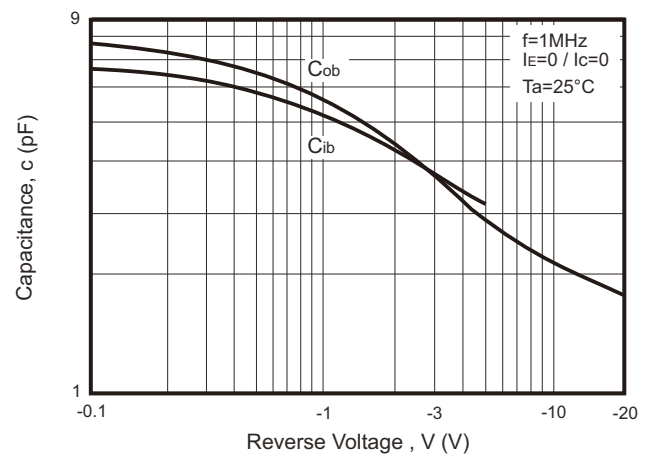

Fig. 7- $f_r - I_c$

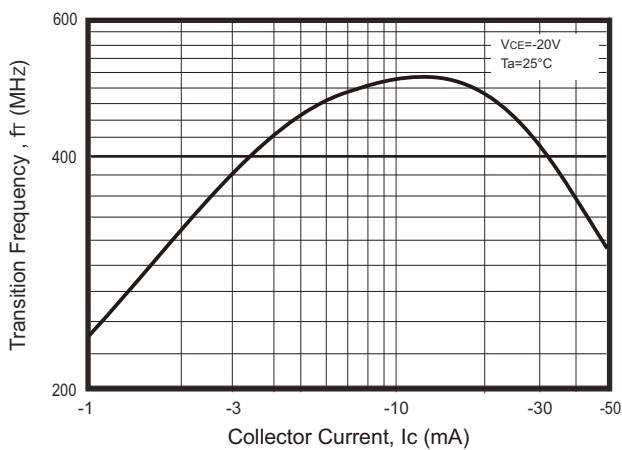
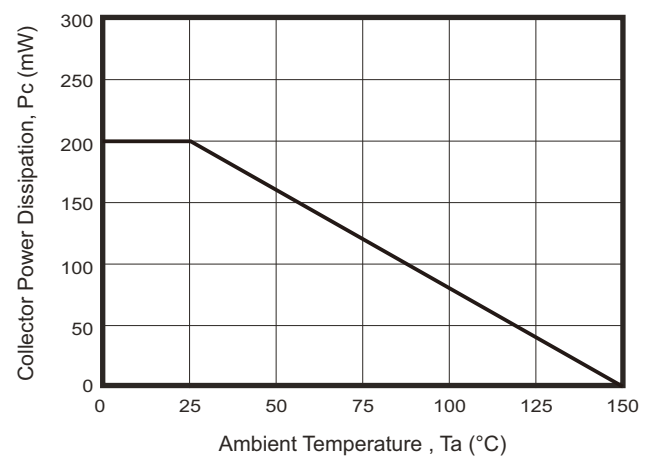
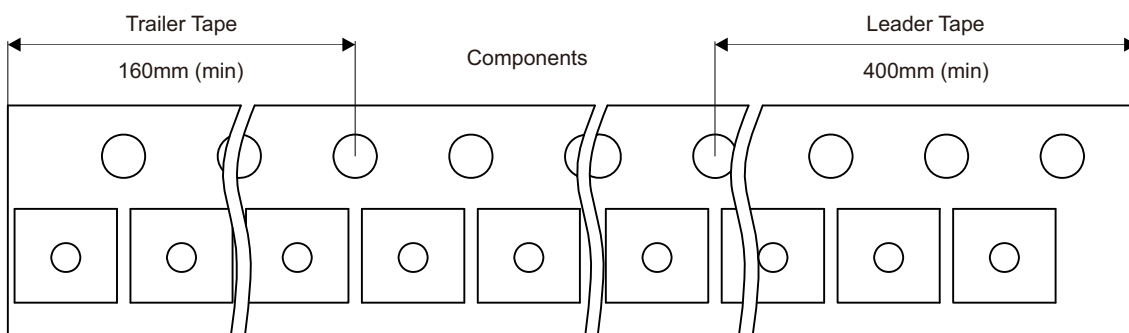
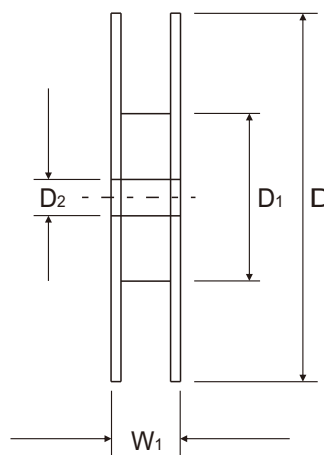
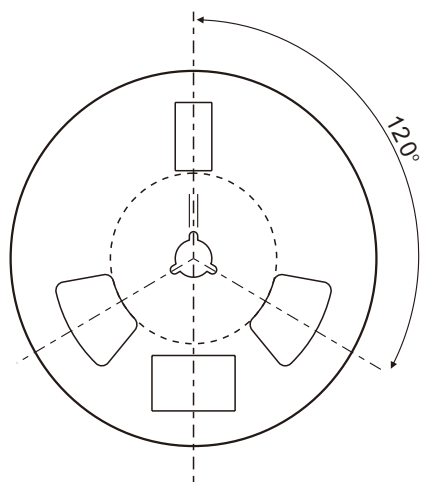
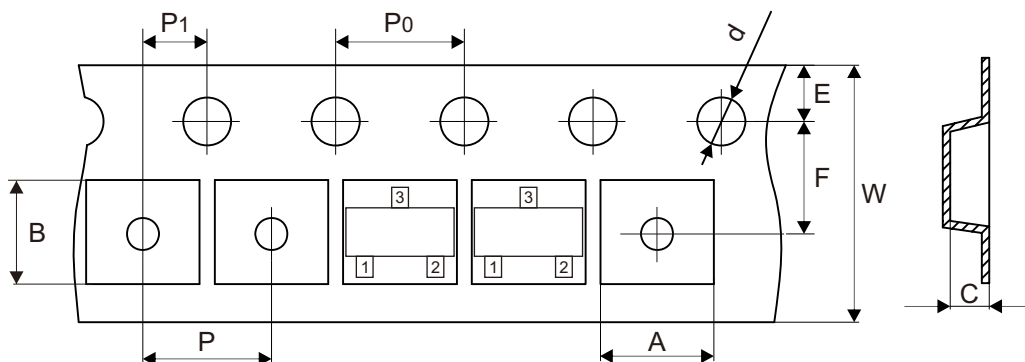

Fig. 8 - $P_c - T_a$



Reel Taping Specification



SOT-23	SYMBOL	A	B	C	d	D	D1	D2
	(mm)	3.15 ± 0.10	2.77 ± 0.10	1.22 ± 0.10	1.50 ± 0.10	178 ± 1.00	54.40 ± 0.40	13.00 ± 0.20
	(inch)	0.124 ± 0.004	0.109 ± 0.004	0.048 ± 0.004	0.059 ± 0.004	7.008 ± 0.039	2.142 ± 0.016	0.512 ± 0.008

SOT-23	SYMBOL	E	F	P	P0	P1	W	W1
	(mm)	1.75 ± 0.10	3.50 ± 0.05	4.00 ± 0.10	4.00 ± 0.10	2.00 ± 0.10	8.00 + 0.30 / - 0.10	9.50 ± 1.00
	(inch)	0.069 ± 0.004	0.138 ± 0.002	0.157 ± 0.004	0.157 ± 0.004	0.079 ± 0.004	0.315 + 0.012 / - 0.004	0.374 ± 0.039

Marking Code

Part Number	Marking Code	
MMBT3906-HF	2A	2Ay

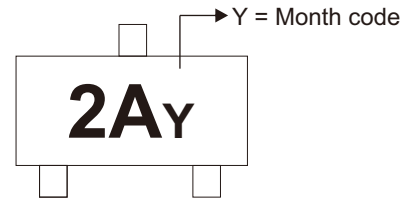

2A = Product marking code

Month Code: (2 years a cycle)

Month	Odd Year (per A.D.)	Even Year (per A.D.)
Jan	J	W
Feb	O	N
Mar	L	Y
Apr	C	T
May	K	R
Jun	B	H

Month	Odd Year (per A.D.)	Even Year (per A.D.)
Jul	P	A
Aug	D	I
Sep	M	U
Oct	E	X
Nov	G	Z
Dec	F	S

Suggested P.C.B. PAD Layout

SIZE	SOT-23	
	(mm)	(inch)
A	0.90	0.035
B	0.80	0.031
C	0.95	0.037
D	2.00	0.079
E	2.90	0.114

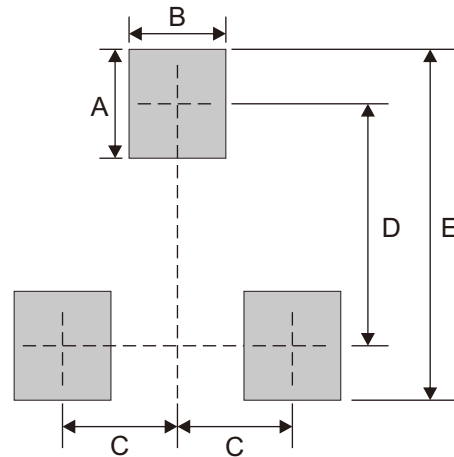

Note: 1. The pad layout is for reference purposes only.

Standard Packaging

Case Type	REEL PACK	
	REEL (pcs)	Reel Size (inch)
SOT-23	3,000	7